

MODEL 440 & 450 ROTARY BLADE GRINDER

OWNER'S MANUAL



WARNING

You must thoroughly read and understand this manual before operating the equipment, paying particular attention to the Warning & Safety instructions.

SAFETY INSTRUCTIONS

Safety Awareness Symbols are inserted into this manual to alert you to possible **Safety Hazards**. Whenever you see these symbols, follow their instructions.



The **Warning Symbol** identifies special instructions or procedures which, if not correctly followed, could result in personal injury.



The **Caution Symbol** identifies special instructions or procedures which, if not strictly observed, could result in damage to or destruction of equipment.

1. **KEEP GUARDS IN PLACE** and in working order.
2. **REMOVE WRENCHES AND OTHER TOOLS.**
3. **KEEP WORK AREA CLEAN.**
4. **DON'T USE IN DANGEROUS ENVIRONMENT.** Don't use grinder in damp or wet locations. Machine is for indoor use only. Keep work area well lit.
5. **KEEP ALL VISITORS AWAY.** All visitors should keep a safe distance from work area.
6. **MAKE WORK AREA CHILD-PROOF** with padlocks or master switches.
7. **DON'T FORCE THE GRINDER.** It will do the job better and safer if used as specified in this manual.
8. **USE THE RIGHT TOOL.** Don't force the grinder or an attachment to do a job for which it was not designed.
9. **WEAR PROPER APPAREL.** Wear no loose clothing, gloves, neckties, or jewelry which may get caught in moving parts. Nonslip footwear is recommended. Wear protective hair covering to contain long hair.
10. **ALWAYS USE SAFETY GLASSES.**
11. **DO NOT OVERREACH.** Keep proper footing and balance at all times.
12. **MAINTAIN GRINDER WITH CARE.** Follow instructions in this manual for lubrication and preventive maintenance.
13. **DISCONNECT POWER BEFORE SERVICING,** or when changing the grinding wheel.
14. **REDUCE THE RISK OF UNINTENTIONAL STARTING.** Make sure the switch is OFF before plugging in the grinder.
15. **USE RECOMMENDED ACCESSORIES.** Consult the manual for recommended accessories. Using improper accessories may cause risk of personal injury.
16. **CHECK DAMAGED PARTS.** A guard or other part that is damaged or will not perform its intended function, should be properly repaired or replaced.
17. **NEVER LEAVE GRINDER RUNNING UNATTENDED. TURN POWER OFF.** Do not leave grinder until it comes to a complete stop.
18. **KNOW YOUR EQUIPMENT.** Read this manual carefully. Learn its application and limitations as well as specified potential hazards.
19. **KEEP ALL SAFETY DECALS CLEAN AND LEGIBLE.** If safety decals become damaged or illegible for any reason, replace immediately. Refer to replacement parts illustrations in this manual for the proper location and part numbers of safety decals.
20. **DO NOT OPERATE THE GRINDER WHEN UNDER THE INFLUENCE OF DRUGS, ALCOHOL, OR MEDICATION.**

SAFETY INSTRUCTIONS



IMPROPER USE OF GRINDING WHEEL MAY CAUSE BREAKAGE AND SERIOUS INJURY.

Grinding is a safe operation if the few basic rules listed below are followed. These rules are based on material contained in the ANSI B7.1 Safety Code for "Use, Care and Protection of Abrasive Wheels". For your safety, we suggest you benefit from the experience of others and carefully follow these rules.

DO

1. **DO** always **HANDLE AND STORE** wheels in a **CAREFUL** manner.
2. **DO VISUALLY INSPECT** all wheels before mounting for possible damage.
3. **DO CHECK MACHINE SPEED** against the established maximum safe operating speed marked on wheel.
4. **DO CHECK MOUNTING FLANGES** for equal and correct diameter.
5. **DO USE MOUNTING BLOTTERS** when supplied with wheels.
6. **DO** be sure **WORK REST** is properly adjusted.
7. **DO** always **USE A SAFETY GUARD COVERING** at least one-half of the grinding wheel.
8. **DO** allow **NEWLY MOUNTED WHEELS** to run at operating speed, with guard in place, for at least one minute before grinding.
9. **DO** always **WEAR SAFETY GLASSES** or some type of eye protection when grinding.
10. **DO TURN OFF COOLANT** before stopping to avoid creating an out-of-balance condition.

DON'T

1. **DON'T** use a cracked wheel or one that **HAS BEEN DROPPED** or has become damaged.
2. **DON'T FORCE** a wheel onto the machine **OR ALTER** the size of the mounting hole - if wheel won't fit the machine, get one that will.
3. **DON'T** ever **EXCEED MAXIMUM OPERATING SPEED** established for the wheel.
4. **DON'T** use mounting flanges on which the bearing surfaces **ARE NOT CLEAN, FLAT AND FREE OF BURRS**.
5. **DON'T TIGHTEN** the mounting nut excessively.
6. **DON'T** grind on the **SIDE OF THE WHEEL** (see Safety Code B7.2 for exception).
7. **DON'T** start the machine until the **WHEEL GUARD IS IN PLACE**.
8. **DON'T JAM** work into the wheel.
9. **DON'T STAND DIRECTLY IN FRONT** of a grinding wheel whenever a grinder is started.
10. **DON'T FORCE GRINDING** so that motor slows noticeably or work gets hot.
11. **DO NOT** Powerwash machine.



AVOID INHALATION OF DUST generated by grinding and cutting operations. Exposure to dust may cause respiratory ailments. Use approved NIOSH or MSHA respirators, safety glasses or face shields, and protective clothing. Provide adequate ventilation to eliminate dust, or to maintain dust level below the Threshold. Limit Value for nuisance dust as classified by OSHA.

SAFETY INSTRUCTIONS

This machine is intended for rotary blade grinding ONLY. Any use other than this may cause personal injury and void the warranty.



To assure the quality and safety of your machine and to maintain the warranty, you **MUST** use original equipment, manufacturers replacement parts and have any repair work done by a qualified professional.



ALL operators of this equipment must be thoroughly trained BEFORE operating the equipment.

Do not use compressed air to clean grinding dust from the machine. This dust can cause personal injury as well as damage to the grinder. Machine is for indoor use only. Do NOT Powerwash machine.

MACHINE SPECIFICATIONS

Motor	440- 1/2 HP 115/230 Volt 50/60 Hz, 1 Phase 450- 1 HP 115/230 Volt 50/60 Hz, 1 Phase
Grinding Wheel	8" Diameter x 1.00" Wide - 24 Grit
Maximum Blade Length	Any Length
Sound Level	Greater than 85 Dba when operating.

DAILY MAINTENANCE

On a weekly basis, clean the rotary blade grinder by wiping it off.

On a weekly basis, inspect the grinder for loose fasteners or components.

Approximately every 40 hours of operation, remove the front blade support base and grinding wheel. Then clean the inside of the grinder by wiping it off.



DO NOT USE COMPRESSED AIR TO CLEAN GRINDING DUST FROM GRINDER.

UNPACK THE CARTON

Use care when unpacking. Open box, remove the contents and lay parts out on a table.

Check components against the Parts List on Page 11 to insure all parts were shipped and are in working order.

Inspect all items for shipping damage as they are removed from the shipping containers. If you find any damage, notify the carrier's claims agent and do not proceed with unpacking until the damage has been inspected by the agent. Refer also to the "Shipping Receiving Instructions" packed with this unit.

Install grinder in a dry indoor area with adequate lighting and ventilation.

WIRING INSTRUCTIONS

IMPORTANT GROUNDING INSTRUCTIONS

In case of a malfunction or breakdown, grounding reduces the risk of electrical shock by providing a path of least resistance for electrical shock.

This Grinder has an electrical cord with an equipment grounding conductor and a grounding plug. The plug must be plugged into a matching outlet that is properly installed and grounded according to all local or other appropriate electrical codes and ordinances.

Before plugging in the Grinder, make sure it will be connected to a supply circuit protected by a properly-sized circuit breaker or fuse. 10 amp minimum for 115V application.

115 Volt Model Only.
Plug the power cord into standard grounded receptacle as shown:



DO NOT MODIFY THE PLUG PROVIDED WITH THE MACHINE; IF IT WILL NOT FIT THE OUTLET, HAVE A PROPER OUTLET AND CIRCUIT INSTALLED BY A QUALIFIED ELECTRICIAN.



FIG. 1

Always provide a proper electrical ground for your machine. An improper connection can cause a dangerous electrical shock. If you are unsure of the proper electrical grounding procedure, contact a qualified electrician.

PLEASE TAKE SPECIAL NOTE OF THE FOLLOWING WARNING DECALS LOCATED ON THE FRONT AND SIDES OF THE GRINDER.

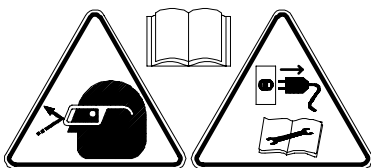

Symbol for Read operators manual, wear safety glasses and disconnect power before servicing.



Symbol to keep visitors a safe distance away from the grinder.



Symbol for sharp object which will cause serious injury.



Symbol identifying a panel, cover, or area as having live electrical components within.



Symbol for minimum safe rated RPM of grinding wheel.



Symbol for hearing protection required when operating this machine.

OPERATING INSTRUCTIONS

Follow these instructions, to correctly sharpen Rotary Lawn Mower Blades.

1. CLEANING

A rotary mower blade which has a buildup of dirt and dried grass clippings cannot be properly sharpened or balanced.

To clean your blade follow these steps:

1. Put on safety glasses.
2. Scrape off the heavy grass buildup with a flat scraper.
3. Use a wire wheel on a bench grinder or a wire brush by hand to finish cleaning.

2. INSPECT THE BLADE

If the blade is bent, twisted, or cracked, it must be replaced. See FIG. 3.

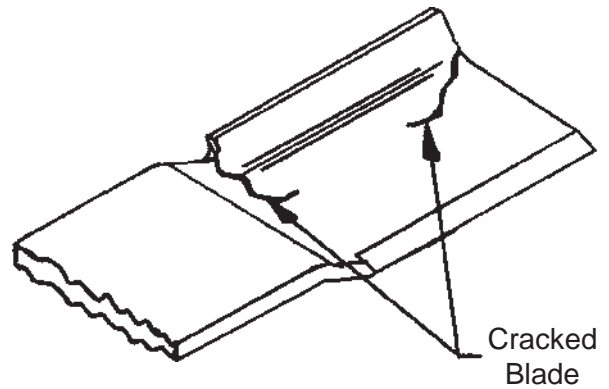

FIG. 3



DO NOT ATTEMPT TO STRAIGHTEN OR REPAIR A BENT, CRACKED, OR TWISTED BLADE. THE USE OF SUCH A BLADE COULD PRESENT A SERIOUS SAFETY RISK.

3. GRINDING



READ AND FOLLOW ALL SAFETY PROCEDURES ON PAGES 2 AND 3.

- A. With the motor off, adjust the angle of the blade guide so the wheel surface is in contact with the rotary mower blade. See FIG. 5. Match the angle of the cutting edge whenever possible. The cutting edge angle should be approximately 30°. If it is not, adjust the blade guide until the desired bevel is achieved. Adjust the guide for minimum space between grinding wheel and guide.

NOTE: Because of the relationship of the grinding wheel to the blade guide during grinding, this grinder will give a slightly concave surface. See FIG. 4. This is normal and acceptable.

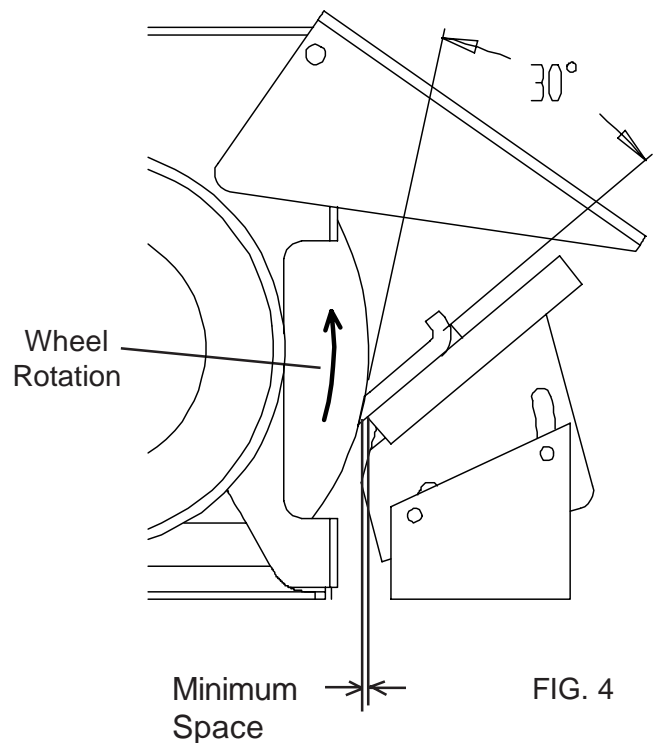

FIG. 4



SAFETY GLASSES AND GUARDS MUST BE IN PLACE, AND ALL FLAMEABLES REMOVED FROM AREA BEFORE OPERATING GRINDER.

ROTATE SPARK SHEILD DOWN BEFORE GRINDING.

NEVER STAND IN LINE WITH GRINDING WHEEL, OPERATE FROM SIDE.

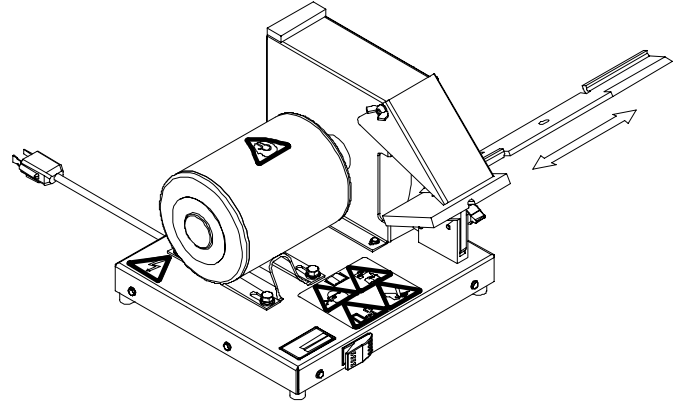

FIG. 5

- B. Turn on the motor. The grinding wheel will rotate upward so that the wheel is turning toward the blade. See 4.

For blades that rotate clockwise, insert the blade from the Wheel Guard side to the grinder. See FIG 6

For blades that rotate counter-clockwise, insert the blade from the Motor side of the grinder. See FIG 7

- C. Holding the blade firmly, move the blade from the center to the outside end in a smooth, even motion until the blade is sharp. See FIG. 5.



FIG. 6

NOTE: If the blade is burning or blueing while sharpening, use lighter strokes. Also, keep the grinding wheel dressed and clean at all times to prevent heat buildup. A grinding wheel slightly rounded on the edge should run a little cooler than one dressed flat. The Dressing Stick is Part No. 3702508 -- .75 x .75 x 3.00 inches.



FIG. 7

- D. Grind the blade the same amount at each end. Use slow, even passes across the grinding wheel. The cutting edge angle should be about 30° after grinding. Several passes are generally necessary to clean up the cutting edge of the blade.

NOTE: A 30° bevel on the sharpened edge is an ideal bevel--a 15° bevel would be too sharp and dull very rapidly. A 45° bevel is too blunt. See FIG. 6.

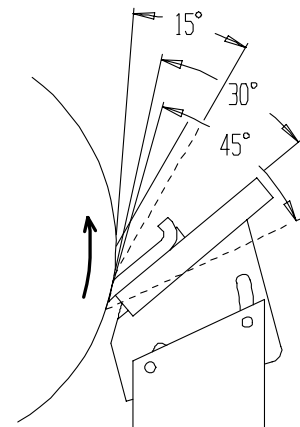

FIG. 6

OPERATING INSTRUCTIONS (Continued)

E. REMOVING BURR

When the blade has been sharpened, stroke the bottom of the cutting edge of the blade across a deburring stone to remove any burr buildup. A flat file may also be used to remove the burr. See FIG 9.

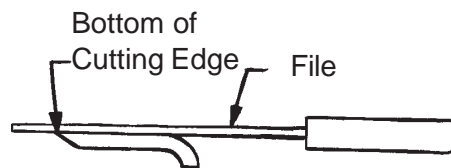

FIG. 9

F. BLADES WITH NONPARALLEL CUTTING EDGE AND "S" STYLE BLADES

Rotary mower cutting blades with the cutting edge at an angle to the body of the blade and "S" style blades must be ground by holding the blade in the same way as shown in FIG. 5 except the blade must be held at an angle to the grinding wheel. This will permit the cutting edge of the blade to be at a right angle to the grinding wheel. By maintaining this angle and by moving the blade from center to the outside end, a uniform cutting edge will be ground.

G. MULCHING BLADES

For mulching blades, remove the blade guide and use the rounded edge of the adjustable support as the guide. See FIG 10



FIG. 10

H. BALANCING THE BLADE

Check the balance of the blade by placing it on the balancer. The blade need not be perfectly balanced. If the blade is held level and after releasing, the end drops less than 1", the balance is satisfactory for ordinary use on most rotary lawn mowers.

Ordinarily the blade can be balanced by grinding just the cutting edge of the heavier end.

I. GUIDE FOR SMALL ENGINE VALVES

Use the hole located on the Wheel Guard Cover for adjusting the length of valve stems. See FIG 11.

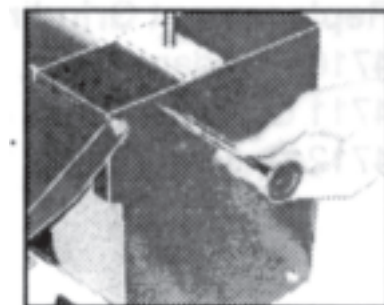

FIG. 11

Grinding Wheel Installation: When installing a new grinding wheel, it is important to follow the instructions provided by the grinding wheel manufacturer. These instructions include the following important points:

1. Always unplug the grinder before installing the new wheel.
2. Read and follow safety instructions on page 3.
3. Look at the threads on the wheel mounting adapter or hub. They are left hand thread.
4. Remove the old wheel and install the new wheel. Make sure the wheel mounting nut is tight, but not so tight as to crack the wheel by crushing it between the flanges.
5. Make sure all guards are in place. Wear Safety Goggles. Keep hands away from the wheel.
6. Start the grinder and check for excessive vibration. If you have vibration, loosen the mounting nut and rotate the grinding wheel approximately 90 ° in relationship to the adapter shaft. Tighten nut and reinstall guards, then retest for vibration. If necessary repeat rotation up to two more times. When the wheel is mounted in the best position, it may also be “dressed” for truth across the grinding surface.
7. If reasonable balance is not attained after trying four positions on the grinding adapter 90 degrees apart, the wheel may not be properly balanced from the factory and should be returned for replacement.

DRESSING THE GRINDING WHEEL

From time to time, the grinding wheel may build up steel particles in the grinding surface and will need to be dressed. Each machine is supplied with one dressing stick. While the grinder is running, hold this brick in the grinder the same way you grind a blade. Move the brick back and forth until the surface of the wheel is free of debris.



ALWAYS WEAR SAFETY GOGGLES WHEN DRESSING A WHEEL.

Wiring Diagram for 1/2 Hp Model 440 with 09922 Motor

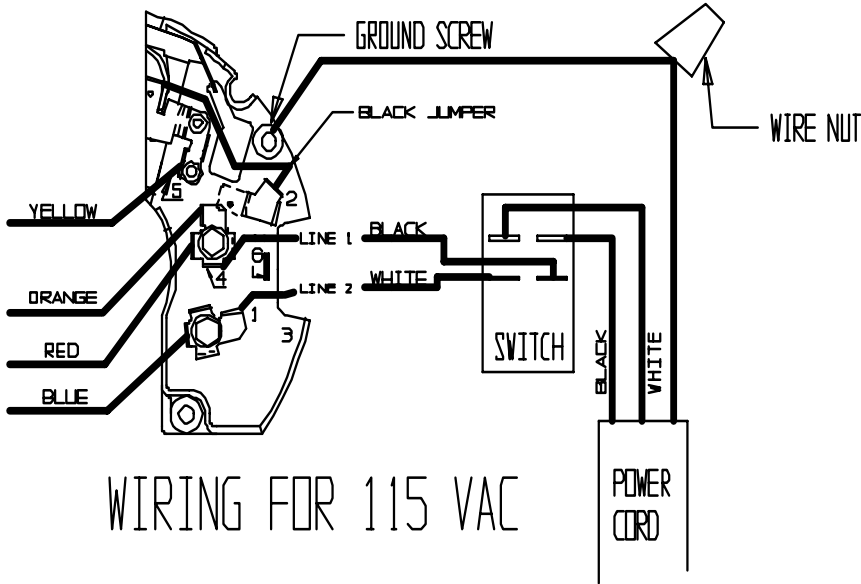

WIRING FOR 115 VAC

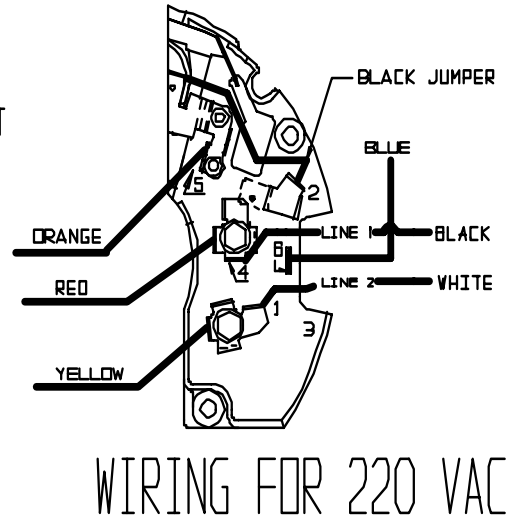

WIRING FOR 220 VAC

Wiring Diagram for 1 HP Model 450 with 09393 Motor

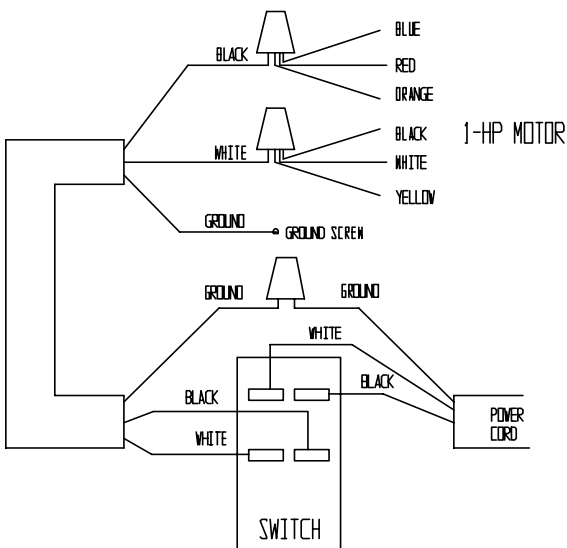

WIRING FOR 115 VAC

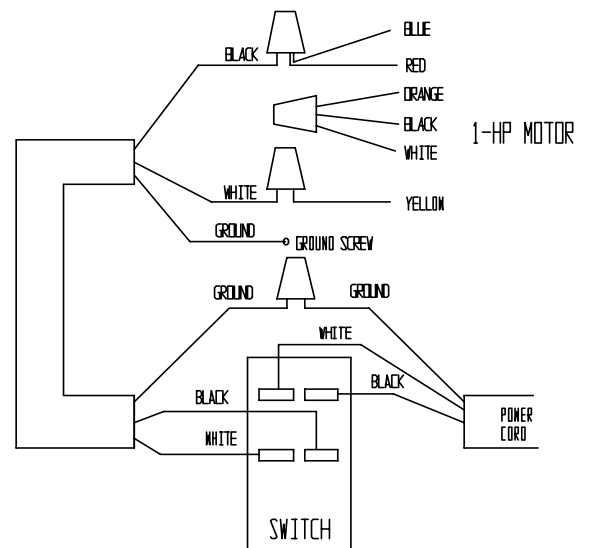

WIRING FOR 220 VAC

EXPLODED VIEW AND PARTS LIST

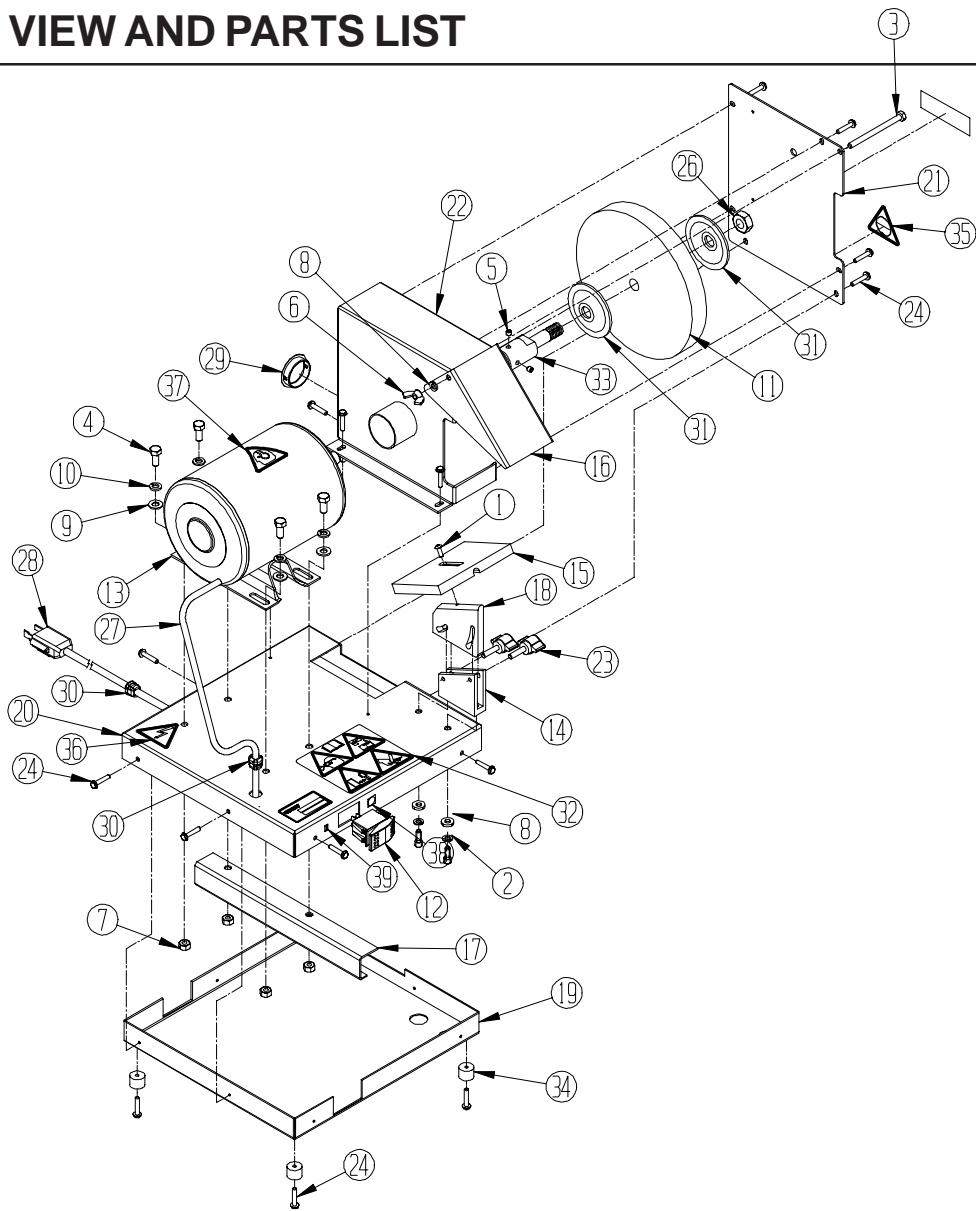

Dia. No.	Part No.	Description
1	B190834	10-32 x 1/2 Button Head Socket Cap Screw
2	B250801	1/4-20 x 1/2 Hex Head Cap Screw
3	B255601	1/4-20 x 3 1/2 Hex Head Cap Screw
4	B311201	5/16-18 x 3/4 Hex Head Cap Screw
5	C250460	1/4-28 x 1/4 Socket Head Set Screw
6	J253000	1/4-20 Wing Nut
7	J311000	5/16-18 Hex Nut Full
8	K251501	1/4 Lockwasher
9	K310001	5/16 SAE Flat Washer
10	K311501	5/16 Lockwasher
11	3700077	8" OD x 1" Wide-Grey Grind Wheel - 24 Grit
	04711	8" OD x 1" Wide-Ruby Grind Wheel - 46 Grit
12	09883	On/Off Switch
13	09922	1/2 HP Motor
	3707590	1HP Motor (Model 450 Grinder)
14	40054	Pivot Support Guide
15	40056	Guide
16	40060	Spark Deflector
17	40062	Frame Brace
18	44052	Pivot Plate
19	44053	Base Bottom
20	44054	Base Top
21	44055	Wheel Guard Cover - Maroon
	44056	Wheel Guard Cover - Light Green
	44062	Wheel Guard Cover - Forest Green

Dia. No.	Part No.	Description
22	44057	Wheel Guard - Maroon
	44058	Wheel Guard - Light Green
	44063	Wheel Guard - Forest Green
23	80053	2-Prong Knob
24	80141	#10 x 5/8 Self Tapping Screw
26	80164	5/8-11 Left Hand Hex Nut - Thin
27	80234	Motor to Switch Cord 1/2 HP
	80393	Motor to Switch Cord 1 HP
28	80235	Main Power Cord
29	80400	Plug - Vac Hole
30	3707273	Stain Relief
31	3708514	Wheel Flange
32	3708703	Warning Decal
33	40063	Adapter
34	3709767	Rubber Bumper
35	3708461	Decal - Wheel RPM Warning
36	3708448	Decal - Electrical Warning
37	3708606	Decal - Hearing Protections
38	3708459	Decal - STOP
39	3708460	Decal - START
	Not Shown.....09700.....	Blade Balancer
	Not Shown.....3702508.....	Dressing Stick
	Not Shown.....3707416.....	Strain Relief 1HP Cord/Motor
	Not Shown.....3707155.....	Wire Nut 1 HP Motor Leads

THIS PAGE LEFT INTENTIONALLY BLANK FOR NOTE TAKING PURPOSES